

Name: \_\_\_\_\_

1. \_\_\_\_ According to the wave-mechanical model of the atom, electrons in an atom  
(1) travel in defined circles (3) have a positive charge  
(2) are most likely found in an excited state (4) are located in orbitals outside the nucleus

2. \_\_\_\_ What is the total charge of the nucleus of a carbon atom?  
(1) -6 (2) 0 (3) +6 (4) +12

3. \_\_\_\_ When an atom loses one or more electrons, this atom becomes a  
(1) positive ion with a radius smaller than the radius of this atom  
(2) positive ion with a radius larger than the radius of this atom  
(3) negative ion with a radius smaller than the radius of this atom  
(4) negative ion with a radius larger than the radius of this atom



4. \_\_\_\_ Which electron configuration could represent a strontium atom in an excited state?  
(1) 2-8-18-7-1 (3) 2-8-18-8-1  
(2) 2-8-18-7-3 (4) 2-8-18-8-2

5. \_\_\_\_ Which grouping of circles, when considered in order from the top to the bottom, best represents the relative size of the atoms of Li, Na, K, and Rb, respectively?

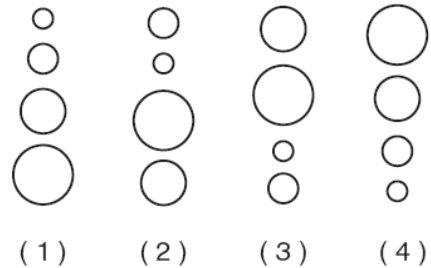

6. \_\_\_\_ What is the total number of neutrons in an atom of  $^{57}_{26}\text{Fe}$ ?  
(1) 26 (2) 31 (3) 57 (4) 83

7. \_\_\_\_ Compared to an electron in the first electron shell of an atom, an electron in the third shell of the same atom has  
(1) less mass (2) less energy (3) more mass (4) more energy

8. \_\_\_\_ An atom in the ground state contains a total of 5 electrons, 5 protons, and 5 neutrons. Which Lewis electron-dot diagram represents this atom?

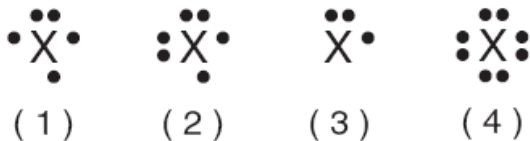

9. Determine the percent composition by mass of oxygen in the compound  $\text{C}_6\text{H}_{12}\text{O}_6$ .

10. \_\_\_\_ What was concluded about the structure of the atom as the result of the gold foil experiment?  
(1) A positively charged nucleus is surrounded by positively charged particles.  
(2) A positively charged nucleus is surrounded by mostly empty space.  
(3) A negatively charged nucleus is surrounded by positively charged particles.  
(4) A negatively charged nucleus is surrounded by mostly empty space.

11. \_\_\_\_ An atom is electrically neutral because the  
(1) number of protons equals the number of electrons  
(2) number of protons equals the number of neutrons  
(3) ratio of the number of neutrons to the number of electrons is 1:1  
(4) ratio of the number of neutrons to the number of protons is 2:1

Name: \_\_\_\_\_

12. \_\_\_\_ How do the energy and the most probable location of an electron in the third shell of an atom compare to the energy and the most probable location of an electron in the first shell of the same atom?  
(1) In the third shell, an electron has more energy and is closer to the nucleus.  
(2) In the third shell, an electron has more energy and is farther from the nucleus.  
(3) In the third shell, an electron has less energy and is closer to the nucleus.  
(4) In the third shell, an electron has less energy and is farther from the nucleus.
13. \_\_\_\_ An ion of which element has a larger radius than an atom of the same element?  
(1) aluminum                      (2) chlorine                      (3) magnesium                      (4) sodium
14. \_\_\_\_ What is the net charge on an ion that has 9 protons, 11 neutrons, and 10 electrons?  
(1) 1+                      (2) 2+                      (3) 1-                      (4) 2-
15. \_\_\_\_ Which two particles make up most of the mass of a hydrogen-2 atom?  
(1) electron and neutron                      (3) proton and neutron  
(2) electron and proton                      (4) proton and positron

16. Write an electron configuration for an atom of aluminum-27 in an excited state.

Base your answers to questions 17 through 19 on the information below.

The accepted values for the atomic mass and percent natural abundance of each naturally occurring isotope of silicon are given in the data table below.

**Naturally Occurring Isotopes of Silicon**

Isotope	Atomic Mass (atomic mass units)	Percent Natural Abundance (%)
Si-28	27.98	92.22
Si-29	28.98	4.69
Si-30	29.97	3.09

17. Determine the total number of neutrons in an atom of Si-29.

18. In the space below, calculate the atomic mass of Si.

19. A scientist calculated the percent natural abundance of Si-30 in a sample to be 3.29%. Determine the percent error for this value.

20. \_\_\_\_ Which quantity identifies an element?  
(1) atomic number                      (3) total number of neutrons in an atom of the element  
(2) mass number                      (4) total number of valence electrons in an atom of the element
21. \_\_\_\_ Which atom in the ground state has a partially filled second electron shell?  
(1) hydrogen atom                      (2) lithium atom                      (3) potassium atom                      (4) sodium atom
22. \_\_\_\_ What is the total charge of the nucleus of a nitrogen atom?  
(1) +5                      (2) +2                      (3) +7                      (4) +14
23. \_\_\_\_ Which value of an element is calculated using both the mass and the relative abundance of each of the naturally occurring isotopes of this element?  
(1) atomic number                      (2) atomic mass                      (3) half-life                      (4) molar volume

Name: \_\_\_\_\_

24. \_\_\_\_ The mass of 12 protons is approximately equal to  
(1) 1 atomic mass unit (3) the mass of 1 electron  
(2) 12 atomic mass units (4) the mass of 12 electrons
25. \_\_\_\_ Which two notations represent different isotopes of the same element?  
(1)  ${}^6_4\text{Be}$  and  ${}^9_4\text{Be}$  (3)  ${}^{14}_7\text{N}$  and  ${}^{14}_6\text{C}$   
(2)  ${}^7_3\text{Li}$  and  ${}^7_3\text{Li}$  (4)  ${}^{32}_{15}\text{P}$  and  ${}^{32}_{16}\text{S}$
26. \_\_\_\_ What is the gram-formula mass of  $\text{Ca}_3(\text{PO}_4)_2$ ?  
(1) 248 g/mol (2) 263 g/mol (3) 279 g/mol (4) 310. g/mol
27. \_\_\_\_ When sodium and fluorine combine to produce the compound  $\text{NaF}$ , the ions formed have the same electron configuration as atoms of  
(1) argon, only (2) neon, only (3) both argon and neon (4) neither argon nor neon
28. Write *one* electron configuration for an atom of silicon in an excited state.

Base your answers to questions 29 through 31 on the information below.

### Atomic Diagrams of Magnesium and Aluminum

Key	Element	Lewis Electron-Dot Diagram	Electron-Shell Diagram
• = electron	magnesium	Mg:	
	aluminum	Al:	

29. Identify *one* piece of information shown in the electron-shell diagrams that is *not* shown in the Lewis electron-dot diagrams.
30. Determine the mass number of the magnesium atom represented by the electron-shell diagram.
31. Explain why Lewis electron-dot diagrams are generally more suitable than electron-shell diagrams for illustrating chemical bonding.

Name: \_\_\_\_\_

- Which two characteristics are associated with metals?  
(1) low first ionization energy and low electronegativity  
(2) low first ionization energy and high electronegativity  
(3) high first ionization energy and low electronegativity  
(4) high first ionization energy and high electronegativity
- Which element is most chemically similar to chlorine?  
(1) Ar (2) F (3) Fr (4) S
- At STP, which element is brittle and *not* a conductor of electricity?  
(1) S (2) K (3) Na (4) Ar

Base your answers to questions 4 through 7 on the information below.

The table below lists physical and chemical properties of six elements at standard pressure that correspond to known elements on the Periodic Table. The elements are identified by the code letters, *D*, *E*, *G*, *J*, *L*, and *Q*.

**Properties of Six Elements at Standard Pressure**

<u>Element D</u> Density 0.00018 g/cm <sup>3</sup> Melting point -272°C Boiling point -269°C Oxide formula (none)	<u>Element E</u> Density 1.82 g/cm <sup>3</sup> Melting point 44°C Boiling point 280°C Oxide formula E <sub>2</sub> O <sub>5</sub>	<u>Element G</u> Density 0.53 g/cm <sup>3</sup> Melting point 181°C Boiling point 1347°C Oxide formula G <sub>2</sub> O
<u>Element J</u> Density 0.0013 g/cm <sup>3</sup> Melting point -210°C Boiling point -196°C Oxide formula J <sub>2</sub> O <sub>5</sub>	<u>Element L</u> Density 0.86 g/cm <sup>3</sup> Melting point 64°C Boiling point 774°C Oxide formula L <sub>2</sub> O	<u>Element Q</u> Density 0.97 g/cm <sup>3</sup> Melting point 98°C Boiling point 883°C Oxide formula Q <sub>2</sub> O

4. What is the total number of elements in the "Properties of Six Elements at Standard Pressure" table that are solids at STP?

5. An atom of element *G* is in the ground state. What is the total number of valence electrons in this atom?

Letter *Z* corresponds to an element on the Periodic Table other than the six listed elements. Elements *G*, *Q*, *L*, and *Z* are in the same group on the Periodic Table, as shown in the diagram below.

G
Q
L
Z

6. Based on the trend in the melting points for elements *G*, *Q*, and *L* listed in the "Properties of Six Elements at Standard Pressure" table, estimate the melting point of element *Z*, in degrees Celsius.

7. Identify, by code letter, the element that is a noble gas in the "Properties of Six Elements at Standard Pressure" table.

- Which element is a solid at STP and a good conductor of electricity?  
(1) iodine (2) mercury (3) nickel (4) sulfur
- Which element has both metallic and nonmetallic properties?  
(1) Rb (2) Rn (3) Si (4) Sr
- The carbon atoms in graphite and the carbon atoms in diamond have different  
(1) atomic numbers (2) atomic masses (3) electronegativities (4) structural arrangements

Name: \_\_\_\_\_

11. \_\_\_\_ Atoms of which element have the greatest tendency to gain electrons?  
(1) bromine (2) chlorine (3) fluorine (4) iodine
12. \_\_\_\_ Which statement describes a chemical property of the element magnesium?  
(1) Magnesium is malleable. (3) Magnesium reacts with an acid.  
(2) Magnesium conducts electricity. (4) Magnesium has a high boiling point.
13. \_\_\_\_ Which statement explains why sulfur is classified as a Group 16 element?  
(1) A sulfur atom has 6 valence electrons. (3) Sulfur is a yellow solid at STP.  
(2) A sulfur atom has 16 neutrons. (4) Sulfur reacts with most metals.
14. \_\_\_\_ How do the atomic radius and metallic properties of sodium compare to the atomic radius and metallic properties of phosphorus?  
(1) Sodium has a larger atomic radius and is more metallic.  
(2) Sodium has a larger atomic radius and is less metallic.  
(3) Sodium has a smaller atomic radius and is more metallic.  
(4) Sodium has a smaller atomic radius and is less metallic.

Base your answers to questions 15 through 17 on the information below.

Elements with atomic numbers 112 and 114 have been produced and their IUPAC names are pending approval.

However, an element that would be put between these two elements on the Periodic Table has not yet been produced. If produced, this element will be identified by the symbol Uut until an IUPAC name is approved.

15. In the space provided, draw a Lewis electron-dot diagram for an atom of Uut.

16. Determine the charge of an Uut nucleus. Your response must include *both* the numerical value and the sign of the charge.

17. Identify *one* element that would be chemically similar to Uut.

18. \_\_\_\_ Sodium atoms, potassium atoms, and cesium atoms have the same  
(1) atomic radius (3) total number of protons  
(2) first ionization energy (4) oxidation state

19. \_\_\_\_ Which statement describes a chemical property of hydrogen gas?  
(1) Hydrogen gas burns in air. (3) Hydrogen gas has a density of  $0.000\ 09\ \text{g/cm}^3$  at STP.  
(2) Hydrogen gas is colorless. (4) Hydrogen gas has a boiling point of 20. K at standard pressure.

20. \_\_\_\_ Which element has the greatest density at STP?  
(1) calcium (2) carbon (3) chlorine (4) copper

21. \_\_\_\_ Which list of elements consists of metalloids, only?  
(1) B, Al, Ga (2) C, N, P (3) O, S, Se (4) Si, Ge, As

22. \_\_\_\_ Which general trend is found in Period 2 on the Periodic Table as the elements are considered in order of increasing atomic number?  
(1) decreasing atomic mass (3) increasing atomic radius  
(2) decreasing electronegativity (4) increasing first ionization energy

23. Describe *one* chemical property of Group 1 metals that results from the atoms of each metal having only one valence electron.

Name: \_\_\_\_\_

Base your answers to questions 1 and 2 on the information below.

Ozone gas,  $O_3$ , can be used to kill adult insects in storage bins for grain without damaging the grain. The ozone is produced from oxygen gas,  $O_2$ , in portable ozone generators located near the storage bins. The concentrations of ozone used are so low that they do not cause any environmental damage. This use of ozone is safer and more environmentally friendly than a method that used bromomethane,  $CH_3Br$ . However, bromomethane was more effective than ozone because  $CH_3Br$  killed immature insects as well as adult insects.

1. Determine the total number of moles of  $CH_3Br$  in 19 grams of  $CH_3Br$  (gram-formula mass = 95 grams/mol).

2. Based on the information in the passage, state *one* advantage of using ozone instead of bromomethane for insect control in grain storage bins.

Given the balanced equation representing a reaction:

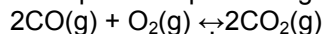

3. \_\_\_\_ What is the mole ratio of  $CO(g)$  to  $CO_2(g)$  in this reaction?

(1) 1:1                      (2) 1:2                      (3) 2:1                      (4) 3:2

4. \_\_\_\_ At STP, which sample contains the same number of molecules as 11.2 liters of  $CO_2(g)$  at STP?

(1) 5.6 L of  $NO_2(g)$                       (2) 7.5 L of  $H_2(g)$                       (3) 11.2 L of  $N_2(g)$                       (4) 22.4 L of  $CO(g)$

Base your answers to questions 5 through 7 on the information below.

In a laboratory activity, 0.500 mole of  $NaOH(s)$  is completely dissolved in distilled water to form 400. milliliters of  $NaOH(aq)$ . This solution is then used to titrate a solution of  $HNO_3(aq)$ .

5. Identify the negative ion produced when the  $NaOH(s)$  is dissolved in distilled water.

6. In the space provided, calculate the molarity of the  $NaOH(aq)$ . Your response must include *both* a correct numerical setup and the calculated result.

7. Complete the equation representing this titration reaction by writing the formulas of the products.



Name: \_\_\_\_\_

8. \_\_\_\_\_ What is the gram-formula mass of  $\text{Ca}_3(\text{PO}_4)_2$ ?  
(1) 248 g/mol      (2) 263 g/mol      (3) 279 g/mol      (4) 310. g/mol
9. \_\_\_\_\_ What is the concentration of  $\text{O}_2(\text{g})$ , in parts per million, in a solution that contains 0.008 gram of  $\text{O}_2(\text{g})$  dissolved in 1000. grams of  $\text{H}_2\text{O}(\text{l})$ ?  
(1) 0.8 ppm      (2) 8 ppm      (3) 80 ppm      (4) 800 ppm

Base your answers to questions ~~8~~<sup>10</sup> through ~~9~~<sup>12</sup> on the information below.  
Some dry chemicals can be used to put out forest fires. One of these chemicals is  $\text{NaHCO}_3$ . When  $\text{NaHCO}_3(\text{s})$  is heated, one of the products is  $\text{CO}_2(\text{g})$ , as shown in the balanced equation below.

10. In the space provided, calculate the percent composition by mass of carbon in the product  $\text{Na}_2\text{CO}_3$ .

11. Identify the type of chemical reaction represented by this equation.

12. Determine the total number of moles of  $\text{CO}_2(\text{g})$  produced when 7.0 moles of  $\text{NaHCO}_3(\text{s})$  is completely reacted.

Name: \_\_\_\_\_

1. \_\_\_\_\_ What is the name of the polyatomic ion in the compound  $\text{Na}_2\text{O}_2$ ?  
(1) hydroxide (2) oxalate (3) oxide (4) peroxide

Given the balanced equation:

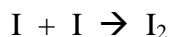

2. \_\_\_\_\_ Which statement describes the process represented by this equation?  
(1) A bond is formed as energy is absorbed. (3) A bond is broken as energy is absorbed.  
(2) A bond is formed and energy is released. (4) A bond is broken and energy is released.
3. \_\_\_\_\_ An oxygen molecule contains a double bond because the two atoms of oxygen share a total of  
(1) 1 electron (2) 2 electrons (3) 3 electrons (4) 4 electrons
4. \_\_\_\_\_ Which formula represents lead(II) chromate?  
(1)  $\text{PbCrO}_4$  (2)  $\text{Pb}(\text{CrO}_4)_2$  (3)  $\text{Pb}_2\text{CrO}_4$  (4)  $\text{Pb}_2(\text{CrO}_4)_3$
5. \_\_\_\_\_ Which pair consists of a molecular formula and its corresponding empirical formula?  
(1)  $\text{C}_2\text{H}_2$  and  $\text{CH}_3\text{CH}_3$  (2)  $\text{C}_6\text{H}_6$  and  $\text{C}_2\text{H}_2$  (3)  $\text{P}_4\text{O}_{10}$  and  $\text{P}_2\text{O}_5$  (4)  $\text{SO}_2$  and  $\text{SO}_3$
6. \_\_\_\_\_ At STP, fluorine is a gas and bromine is a liquid because, compared to fluorine, bromine has  
(1) stronger covalent bonds (3) weaker covalent bonds  
(2) stronger intermolecular forces (4) weaker intermolecular forces
7. Determine the percent composition by mass of oxygen in the compound  $\text{C}_6\text{H}_{12}\text{O}_6$ .

Base your answers to questions 8 and 9 on the information below.

The unbalanced equation below represents the decomposition of potassium chlorate.

8. Balance the equation, using the smallest whole-number coefficients.



9. Explain, in terms of electronegativity, why a P–Cl bond in a molecule of  $\text{PCl}_5$  is more polar than a P–S bond in a molecule of  $\text{P}_2\text{S}_5$ .

10. \_\_\_\_\_ Which polyatomic ion contains the greatest number of oxygen atoms?  
(1) acetate (2) carbonate (3) hydroxide (4) peroxide
11. \_\_\_\_\_ Which formula represents an ionic compound?  
(1)  $\text{H}_2$  (2)  $\text{CH}_4$  (3)  $\text{CH}_3\text{OH}$  (4)  $\text{NH}_4\text{Cl}$
12. \_\_\_\_\_ What is the total number of different elements present in  $\text{NH}_4\text{NO}_3$ ?  
(1) 7 (2) 9 (3) 3 (4) 4
13. \_\_\_\_\_ At standard pressure, a certain compound has a low boiling point and is insoluble in water. At STP, this compound most likely exists as  
(1) ionic crystals (3) nonpolar molecules  
(2) metallic crystals (4) polar molecules

Name: \_\_\_\_\_

Base your answers to questions 14 through 16 on the information below.

A hydrate is a compound that has water molecules within its crystal structure. The formula for the hydrate  $\text{CuSO}_4 \cdot 5\text{H}_2\text{O}(\text{s})$  shows that there are five moles of water for every one mole of  $\text{CuSO}_4(\text{s})$ . When  $\text{CuSO}_4 \cdot 5\text{H}_2\text{O}(\text{s})$  is heated, the water within the crystals is released, as represented by the balanced equation below.

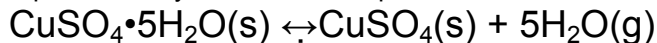

A student first masses an empty crucible (a heat-resistant container). The student then masses the crucible containing a sample of  $\text{CuSO}_4 \cdot 5\text{H}_2\text{O}(\text{s})$ . The student repeatedly heats and masses the crucible and its contents until the mass is constant. The student's recorded experimental data and calculations are shown below.

14. Identify the total number of significant figures recorded in the calculated mass of  $\text{CuSO}_4 \cdot 5\text{H}_2\text{O}(\text{s})$ .

Data and calculation before heating:

mass of $\text{CuSO}_4 \cdot 5\text{H}_2\text{O}(\text{s})$ and crucible	21.37 g
– mass of crucible	19.24 g
<hr/>	
mass of $\text{CuSO}_4 \cdot 5\text{H}_2\text{O}(\text{s})$	2.13 g

15. In the space provided, use the student's data to calculate the percent composition by mass of water in the hydrate.

Data and calculation after heating to a constant mass:

mass of $\text{CuSO}_4(\text{s})$ and crucible	20.61 g
– mass of crucible	19.24 g
<hr/>	
mass of $\text{CuSO}_4(\text{s})$	1.37 g

Calculation to determine the mass of water:

mass of $\text{CuSO}_4 \cdot 5\text{H}_2\text{O}(\text{s})$	2.13 g
– mass of $\text{CuSO}_4(\text{s})$	1.37 g
<hr/>	
mass of $\text{H}_2\text{O}(\text{g})$	0.76 g

16. Explain why the sample in the crucible must be heated until the constant mass is reached.

17. \_\_\_\_ Which term indicates how strongly an atom attracts the electrons in a chemical bond?  
(1) alkalinity                      (2) atomic mass                      (3) electronegativity                      (4) activation energy
18. \_\_\_\_ A solid substance is an excellent conductor of electricity. The chemical bonds in this substance are most likely  
(1) ionic, because the valence electrons are shared between atoms  
(2) ionic, because the valence electrons are mobile  
(3) metallic, because the valence electrons are stationary  
(4) metallic, because the valence electrons are mobile
19. \_\_\_\_ Magnesium nitrate contains chemical bonds that are  
(1) covalent, only                      (3) both covalent and ionic  
(2) ionic, only                      (4) neither covalent nor ionic
20. Write the empirical formula for the compound  $\text{C}_8\text{H}_{18}$ .

Name: \_\_\_\_\_

- \_\_\_\_\_ A sample composed only of atoms having the same atomic number is classified as  
 (1) a compound      (2) a solution      (3) an element      (4) an isomer
- \_\_\_\_\_ Which two particles each have a mass approximately equal to one atomic mass unit?  
 (1) electron and neutron      (3) proton and electron  
 (2) electron and positron      (4) proton and neutron
- \_\_\_\_\_ Which substance can be decomposed by chemical means?  
 (1) ammonia      (2) oxygen      (3) phosphorus      (4) silicon
- \_\_\_\_\_ Which term is defined as a measure of the average kinetic energy of the particles in a sample?  
 (1) temperature      (2) pressure      (3) thermal energy      (4) chemical energy
- \_\_\_\_\_ A dilute, aqueous potassium nitrate solution is best classified as a  
 (1) homogeneous compound      (3) heterogeneous compound  
 (2) homogeneous mixture      (4) heterogeneous mixture

Given the equation representing a phase change at equilibrium:

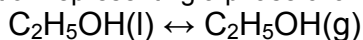

- \_\_\_\_\_ Which statement is true?  
 (1) The forward process proceeds faster than the reverse process.  
 (2) The reverse process proceeds faster than the forward process.  
 (3) The forward and reverse processes proceed at the same rate.  
 (4) The forward and reverse processes both stop.
- \_\_\_\_\_ Which particle diagram represents a sample of one compound, only?

Key	
○	= atom of one element
●	= atom of a different element



(1)



(2)



(3)



(4)

- \_\_\_\_\_ The boiling point of a liquid is the temperature at which the vapor pressure of the liquid is equal to the pressure on the surface of the liquid. What is the boiling point of propanone if the pressure on its surface is 48 kilopascals?  
 (1) 25°C      (2) 30°C      (3) 35°C      (4) 40°C
- \_\_\_\_\_ At which Celsius temperature does lead change from a solid to a liquid?  
 (1) 874°C      (2) 601°C      (3) 328°C      (4) 0°C

Base your answers to questions 10 through 12 on the information below. A gas sample is held at constant temperature in a closed system. The volume of the gas is changed, which causes the pressure of the gas to change. Volume and pressure data are shown in the table below.

10. On the grid provided, mark an appropriate scale on the axis labeled "Volume (mL)."

11. On the same grid, plot the data from the table. Circle and connect the points.

Example:



12. Based on your graph, what is the pressure of the gas when the volume of the gas is 200. milliliters?

Volume and Pressure of a Gas Sample

Volume (mL)	Pressure (atm)
1200	0.5
600	1.0
300	2.0
150	4.0
100	6.0

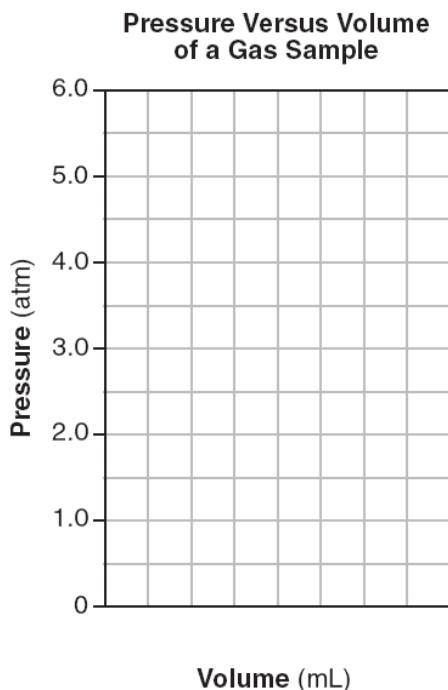

Name: \_\_\_\_\_

Base your answers to questions 13 through 15 on the information below.

A 5.00-gram sample of liquid ammonia is originally at 210. K. The diagram of the partial heating curve below represents the vaporization of the sample of ammonia at standard pressure due to the addition of heat. The heat is *not* added at a constant rate.

Some physical constants for ammonia are shown in the data table below.

**Some Physical Constants for Ammonia**

specific heat capacity of $\text{NH}_3(\ell)$	4.71 J/g•K
heat of fusion	332 J/g
heat of vaporization	1370 J/g

13. In the space provided, calculate the total heat absorbed by the 5.00-gram sample of ammonia during time interval *AB*. Your response must include *both* a correct numerical setup and the calculated result.

14. Describe what is happening to *both* the potential energy and the average kinetic energy of the molecules in the ammonia sample during time interval *BC*. Your response must include *both* potential energy and average kinetic energy.

15. Determine the total amount of heat required to vaporize this 5.00-gram sample of ammonia at its boiling point.

16. A 1.00-mole sample of neon gas occupies a volume of 24.4 liters at 298 K and 101.3 kilopascals. In the space provided, calculate the density of this sample. Your response must include *both* a correct numerical setup and the calculated result.

**Partial Heating Curve for Ammonia**

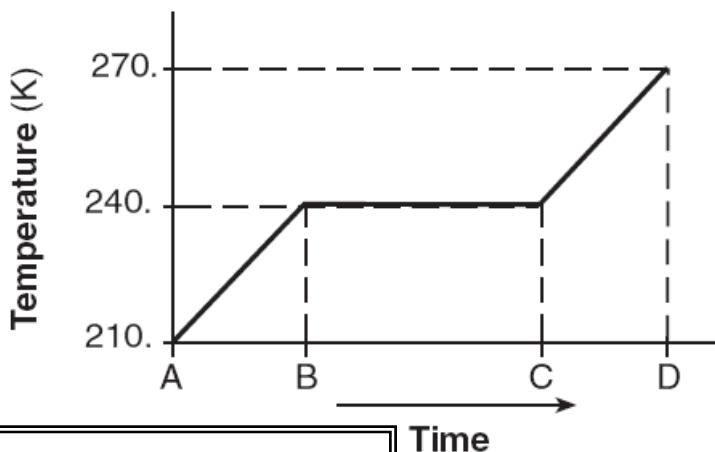

Name: \_\_\_\_\_

Base your answers to questions 17 on the information below.

Propane is a fuel that is sold in rigid, pressurized cylinders. Most of the propane in a cylinder is liquid, with gas in the space above the liquid level. When propane is released from the cylinder, the propane leaves the cylinder as a gas. Propane gas is used as a fuel by mixing it with oxygen in the air and igniting the mixture, as represented by the balanced equation below.

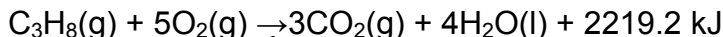

A small amount of methanethiol, which has a distinct odor, is added to the propane to help consumers detect a propane leak. In methanethiol, the odor is caused by the thiol functional group ( $-\text{SH}$ ). Methanethiol,  $\text{CH}_3\text{SH}$ , has a structure that is very similar to the structure of methanol.

17. In the box provided, draw a particle diagram to represent propane in a pressurized cylinder using the key. Your response must include *at least six* molecules of propane in the gas phase and *at least six* molecules of propane in the liquid phase.

Key	
	= propane molecule

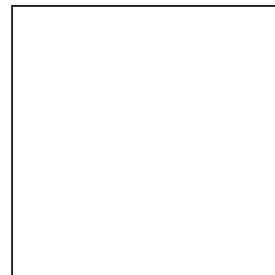

18. \_\_\_\_\_ Matter that is composed of two or more different elements chemically combined in a fixed proportion is classified as

(1) a compound                      (3) a mixture  
(2) an isotope                      (4) a solution

19. \_\_\_\_\_ Which sample of matter is a single substance?

(1) air                      (2) ammonia gas                      (3) hydrochloric acid                      (4) salt water

20. \_\_\_\_\_ A sample of gas is held at constant pressure. Increasing the kelvin temperature of this gas sample causes the average kinetic energy of its molecules to

(1) decrease and the volume of the gas sample to decrease  
(2) decrease and the volume of the gas sample to increase  
(3) increase and the volume of the gas sample to decrease  
(4) increase and the volume of the gas sample to increase

21. \_\_\_\_\_ The table below shows mass and volume data for four samples of substances at 298 K and 1 atmosphere. Which two samples could consist of the same substance?

(1) A and B                      (3) B and C  
(2) A and C                      (4) C and D

**Masses and Volumes of Four Samples**

Sample	Mass (g)	Volume (mL)
A	30.	60.
B	40.	50.
C	45	90.
D	90.	120.

22. \_\_\_\_\_ At standard pressure, a certain compound has a low boiling point and is insoluble in water. At STP, this compound most likely exists as

(1) ionic crystals                      (3) nonpolar molecules  
(2) metallic crystals                      (4) polar molecules

23. \_\_\_\_\_ Which kelvin temperature is equal to  $56^\circ\text{C}$ ?

(1)  $-329 \text{ K}$                       (3)  $217 \text{ K}$   
(2)  $-217 \text{ K}$                       (4)  $329 \text{ K}$

24. \_\_\_\_\_ Which substance can be broken down by a chemical change?

(1) antimony                      (2) carbon                      (3) hexane                      (4) sulfur

25. \_\_\_\_\_ A rigid cylinder with a movable piston contains a 2.0-liter sample of neon gas at STP. What is the volume of this sample when its temperature is increased to  $30.^\circ\text{C}$  while its pressure is decreased to 90. kilopascals?

(1) 2.5 L                      (2) 2.0 L                      (3) 1.6 L                      (4) 0.22 L

Name: \_\_\_\_\_

Base your answers to questions 25 through 29 on the information below.

The temperature of a sample of a substance is increased from 20.°C to 160.°C as the sample absorbs heat at a constant rate of 15 kilojoules per minute at standard pressure. The graph below represents the relationship between temperature and time as the sample is heated.

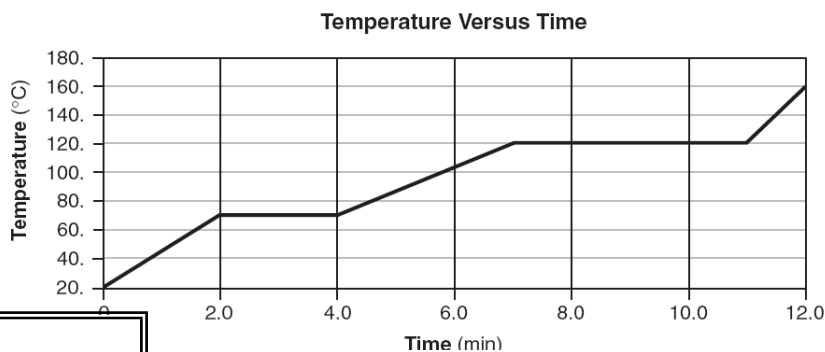

26. What is the boiling point of this sample?

27. In the space provided, use the key to draw *at least nine* particles in the box, showing the correct particle arrangement of this sample during the first minute of heating.

**Key**

○ = particle of the substance

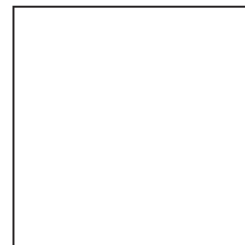

28. What is the total time this sample is in the liquid phase, only?

29. Determine the total amount of heat required to completely melt this sample at its melting point.

The table below shows data for the temperature, pressure, and volume of four gas samples.

**Data for Four Gas Samples**

Gas Sample	Temperature (K)	Pressure (atm)	Volume (mL)
A	100.	2	400.
B	200.	2	200.
C	100.	2	400.
D	200.	4	200.

30. \_\_\_\_ Which two gas samples have the same total number of molecules?

- (1) A and B                      (3) B and C  
 (2) A and C                      (4) B and D

31. \_\_\_\_ At which temperature is the vapor pressure of ethanol equal to the vapor pressure of propanone at 35°C?

- (1) 35°C            (2) 60.°C            (3) 82°C            (4) 95°C

Base your answers to questions 32 through 34 on the information to the right. A 100.0-gram sample of NaCl(s) has an initial temperature of 0°C. A chemist measures the temperature of the sample as it is heated. Heat is *not* added at a constant rate. The heating curve for the sample is shown below.

**Heating Curve for Sodium Chloride**

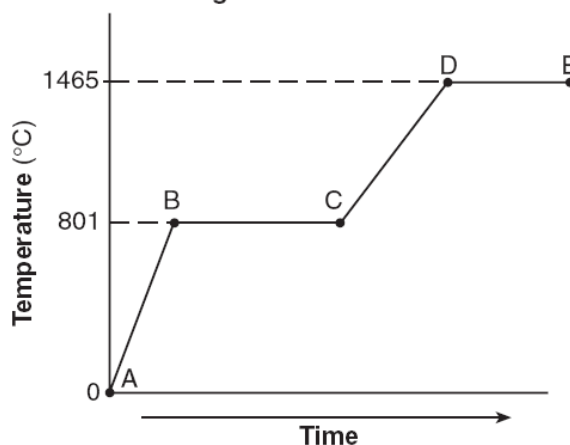

32. Determine the temperature range over which the entire NaCl sample is a liquid.

33. Identify *one* line segment on the curve where the average kinetic energy of the particles of the NaCl sample is changing.

34. Identify *one* line segment on the curve where the NaCl sample is in a single phase and capable of conducting electricity.

Name: \_\_\_\_\_

Base your answers to questions 35 and 36 on the information below.

A student performed an experiment to determine the total amount of energy stored in a peanut. The accepted value for the energy content of a peanut is 30.2 kilojoules per gram. The student measured 100.0 grams of water into a metal can and placed the can on a ring stand, as shown in the diagram below. The peanut was attached to a wire suspended under the can. The initial temperature of the water was recorded as 22.0°C. The peanut was ignited and allowed to burn. When the peanut finished burning, the final water temperature was recorded as 57.0°C. The student's experimental value for the energy content of this peanut was 25.9 kilojoules per gram.

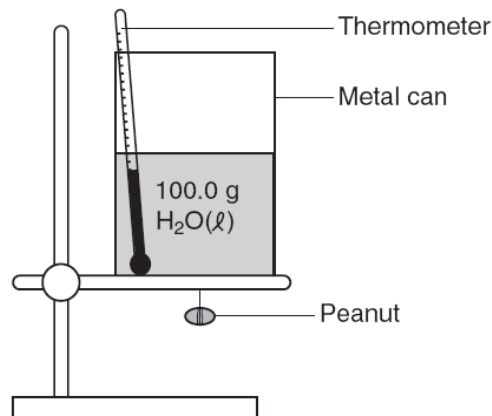

35. In the space provided, calculate the total amount of heat absorbed by the water. Your response must include *both* a correct numerical setup and the calculated result.

36. Determine the student's percent error for the energy content of this peanut.

Base your answers to questions 37 and 38 on the information below.

In an investigation, a dripless wax candle is massed and then lit. As the candle burns, a small amount of liquid wax forms near the flame. After 10 minutes, the candle's flame is extinguished and the candle is allowed to cool. The cooled candle is massed.

Boiling Point Versus Molar Mass of Some Alkanes

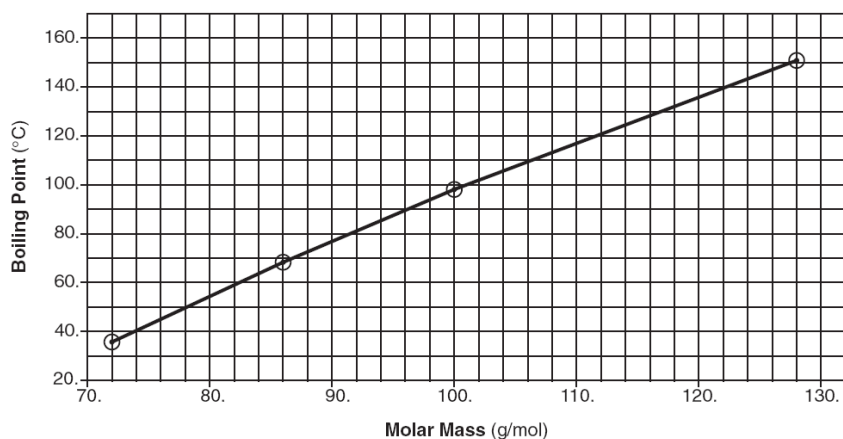

37. Identify *one* physical change that takes place in this investigation.

38. State *one* observation that indicates a chemical change has occurred in this investigation.

Name: \_\_\_\_\_

- \_\_\_\_\_ A 3.0 M HCl(aq) solution contains a total of  
(1) 3.0 grams of HCl per liter of water                      (3) 3.0 moles of HCl per liter of solution  
(2) 3.0 grams of HCl per mole of solution                      (4) 3.0 moles of HCl per mole of water
- \_\_\_\_\_ A dilute, aqueous potassium nitrate solution is best classified as a  
(1) homogeneous compound                      (3) heterogeneous compound  
(2) homogeneous mixture                      (4) heterogeneous mixture

Base your answers to questions 3 through 5 on the information below.

Scientists who study aquatic ecosystems are often interested in the concentration of dissolved oxygen in water. Oxygen, O<sub>2</sub>, has a very low solubility in water, and therefore its solubility is usually expressed in units of milligrams per 1000. grams of water at 1.0 atmosphere. The graph below shows a solubility curve of oxygen in water.

Solubility of Oxygen in Water Versus Temperature

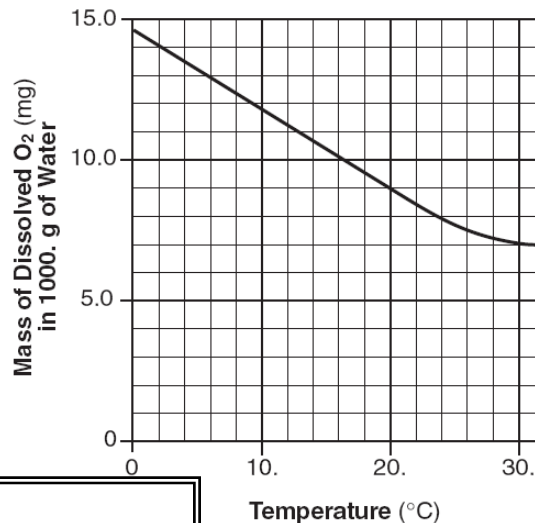

- A student determines that 8.2 milligrams of oxygen is dissolved in a 1000.-gram sample of water at 15°C and 1.0 atmosphere. In terms of saturation, what type of solution is this sample?

- Explain, in terms of molecular polarity, why oxygen gas has low solubility in water. Your response must include *both* oxygen and water.

- An aqueous solution has 0.0070 gram of oxygen dissolved in 1000. grams of water. In the space provided, calculate the dissolved oxygen concentration of this solution in parts per million. Your response must include *both* a correct numerical setup and the calculated result.

- \_\_\_\_\_ Which statement must be true when solution equilibrium occurs?  
(1) The solution is at STP.  
(2) The solution is supersaturated.  
(3) The concentration of the solution remains constant.  
(4) The masses of the dissolved solute and the undissolved solute are equal.
- \_\_\_\_\_ Which liquid has the highest vapor pressure at 75°C?  
(1) ethanoic acid                      (2) ethanol                      (3) propanone                      (4) water
- \_\_\_\_\_ An unsaturated solution is formed when 80. grams of a salt is dissolved in 100. grams of water at 40.°C. This salt could be  
(1) KCl                      (2) KNO<sub>3</sub>                      (3) NaCl                      (4) NaNO<sub>3</sub>
- \_\_\_\_\_ Which barium salt is *insoluble* in water?  
(1) BaCO<sub>3</sub>                      (2) BaCl<sub>2</sub>                      (3) Ba(ClO<sub>4</sub>)<sub>2</sub>                      (4) Ba(NO<sub>3</sub>)<sub>2</sub>

Name: \_\_\_\_\_

10. \_\_\_\_ Which unit can be used to express solution concentration?

- (1) J/mol      (2) L/mol      (3) mol/L      (4) mol/s

11. \_\_\_\_ Under which conditions of temperature and pressure is a gas most soluble in water?

- (1) high temperature and low pressure      (3) low temperature and low pressure  
(2) high temperature and high pressure      (4) low temperature and high pressure

12. \_\_\_\_ As water is added to a 0.10 M NaCl aqueous solution, the conductivity of the resulting solution

- (1) decreases because the concentration of ions decreases  
(2) decreases, but the concentration of ions remains the same  
(3) increases because the concentration of ions decreases  
(4) increases, but the concentration of ions remains the same

Base your answers to questions 13 and 14 on the information below.

A solution is made by completely dissolving 90. grams of  $\text{KNO}_3(\text{s})$  in 100. grams of water in a beaker. The temperature of this solution is  $65^\circ\text{C}$ .

13. Describe the effect on the solubility of  $\text{KNO}_3(\text{s})$  in this solution when the pressure on the solution increases.

14. Determine the total mass of  $\text{KNO}_3(\text{s})$  that settles to the bottom of the beaker when the original solution is cooled to  $15^\circ\text{C}$ .

Name: \_\_\_\_\_

1. \_\_\_\_ A 5.0-gram sample of zinc and a 50.-milliliter sample of hydrochloric acid are used in a chemical reaction. Which combination of these samples has the fastest reaction rate?  
(1) a zinc strip and 1.0 M HCl(aq)                      (3) zinc powder and 1.0 M HCl(aq)  
(2) a zinc strip and 3.0 M HCl(aq)                      (4) zinc powder and 3.0 M HCl(aq)
2. \_\_\_\_ For a given reaction, adding a catalyst increases the rate of the reaction by  
(1) providing an alternate reaction pathway that has a higher activation energy  
(2) providing an alternate reaction pathway that has a lower activation energy  
(3) using the same reaction pathway and increasing the activation energy  
(4) using the same reaction pathway and decreasing the activation energy
3. \_\_\_\_ Which reaction releases the greatest amount of energy per 2 moles of product?  
(1)  $2\text{CO(g)} + \text{O}_2\text{(g)} \rightarrow 2\text{CO}_2\text{(g)}$   
(2)  $4\text{Al(s)} + 3\text{O}_2\text{(g)} \rightarrow 2\text{Al}_2\text{O}_3\text{(s)}$   
(3)  $2\text{H}_2\text{(g)} + \text{O}_2\text{(g)} \rightarrow 2\text{H}_2\text{O(g)}$   
(4)  $\text{N}_2\text{(g)} + 3\text{H}_2\text{(g)} \rightarrow 2\text{NH}_3\text{(g)}$
4. \_\_\_\_ Which changes occur when  $\text{Pt}^{2+}$  is reduced?  
(1) The  $\text{Pt}^{2+}$  gains electrons and its oxidation number increases.  
(2) The  $\text{Pt}^{2+}$  gains electrons and its oxidation number decreases.  
(3) The  $\text{Pt}^{2+}$  loses electrons and its oxidation number increases.  
(4) The  $\text{Pt}^{2+}$  loses electrons and its oxidation number decreases.

Given the equation representing a reaction at equilibrium:

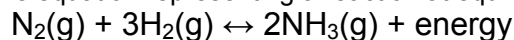

5. \_\_\_\_ Which change causes the equilibrium to shift to the right?  
(1) decreasing the concentration of  $\text{H}_2\text{(g)}$                       (3) increasing the concentration of  $\text{N}_2\text{(g)}$   
(2) decreasing the pressure                                      (4) increasing the temperature
6. Explain, in terms of collision theory, why the rate of a chemical reaction increases with an increase in temperature.

7. On the diagram provided, draw a potential energy diagram for this reaction.

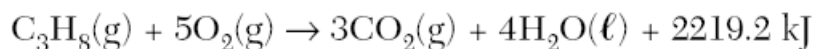

8. Determine the total amount of energy released when 2.50 moles of propane is completely reacted with oxygen.

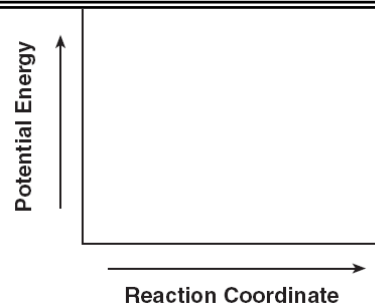

Given the balanced equation representing a reaction:

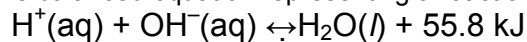

9. \_\_\_\_ In this reaction there is conservation of  
(1) mass, only    (3) mass and energy, only  
(2) mass and charge, only                              (4) mass, charge, and energy

Name: \_\_\_\_\_

10. \_\_\_\_\_ Which statement must be true when solution equilibrium occurs?
- (1) The solution is at STP.
  - (2) The solution is supersaturated.
  - (3) The concentration of the solution remains constant.
  - (4) The masses of the dissolved solute and the undissolved solute are equal.

Given the balanced equation representing a reaction:

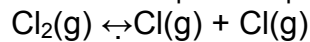

11. \_\_\_\_\_ What occurs during this change?
- (1) Energy is absorbed and a bond is broken.
  - (2) Energy is absorbed and a bond is formed.
  - (3) Energy is released and a bond is broken.
  - (4) Energy is released and a bond is formed.

Given the balanced equation representing a reaction:

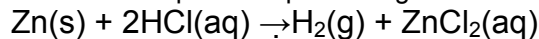

12. \_\_\_\_\_ Which set of reaction conditions produces  $\text{H}_2(\text{g})$  at the fastest rate?
- (1) a 1.0-g lump of  $\text{Zn}(\text{s})$  in 50. mL of 0.5 M  $\text{HCl}(\text{aq})$  at  $20.^\circ\text{C}$
  - (2) a 1.0-g lump of  $\text{Zn}(\text{s})$  in 50. mL of 0.5 M  $\text{HCl}(\text{aq})$  at  $30.^\circ\text{C}$
  - (3) 1.0 g of powdered  $\text{Zn}(\text{s})$  in 50. mL of 1.0 M  $\text{HCl}(\text{aq})$  at  $20.^\circ\text{C}$
  - (4) 1.0 g of powdered  $\text{Zn}(\text{s})$  in 50. mL of 1.0 M  $\text{HCl}(\text{aq})$  at  $30.^\circ\text{C}$

Base your answers to questions 13 through 15 on the reaction represented by the balanced equation below.

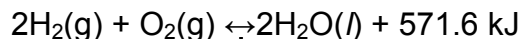

13. Identify the information in this equation that indicates the reaction is exothermic.

14. On the axes provided, draw a potential energy diagram for the reaction represented by this equation.

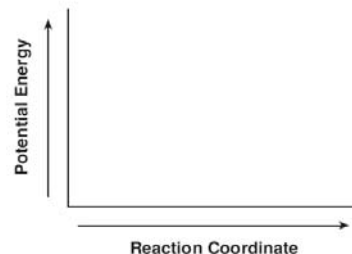

15. Explain why the entropy of the system *decreases* as the reaction proceeds.

Base your answers to questions 16 through 18 on the information below.

Rust on an automobile door contains  $\text{Fe}_2\text{O}_3(\text{s})$ . The balanced equation representing one of the reactions between iron in the door of the automobile and oxygen in the atmosphere is given below.

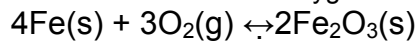

16. Identify the type of chemical reaction represented by this equation.

17. Determine the gram-formula mass of the product of this reaction.

18. Write the IUPAC name for  $\text{Fe}_2\text{O}_3$ .

19. \_\_\_\_\_ Which equation shows conservation of atoms?

- (1)  $\text{H}_2 + \text{O}_2 \rightarrow \text{H}_2\text{O}$
- (2)  $\text{H}_2 + \text{O}_2 \rightarrow 2\text{H}_2\text{O}$
- (3)  $2\text{H}_2 + \text{O}_2 \rightarrow 2\text{H}_2\text{O}$
- (4)  $2\text{H}_2 + 2\text{O}_2 \rightarrow 2\text{H}_2\text{O}$

Given the equation representing a system at equilibrium:

20. \_\_\_\_\_ At which temperature does this equilibrium exist at 101.3 kilopascals?

- (1) 0 K
- (2)  $0^\circ\text{C}$
- (3) 32 K
- (4)  $273^\circ\text{C}$

Name: \_\_\_\_\_

Base your answers to questions 21 and 22 on the information below.

The equilibrium equation below is related to the manufacture of a bleaching solution. In this equation,  $\text{Cl}^-(\text{aq})$  means that chloride ions are surrounded by water molecules.



21. Use the key to draw *two* water molecules in the box, showing the correct orientation of each water molecule toward the chloride ion.

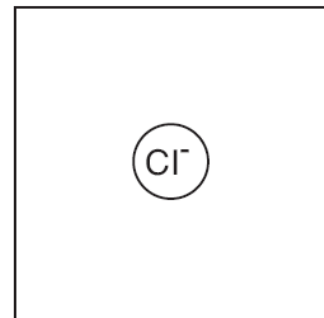
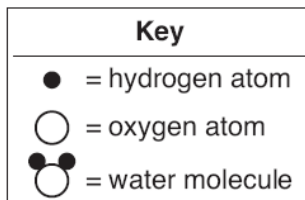

22. Explain, in terms of collision theory, why increasing the concentration of  $\text{Cl}_2(\text{g})$  increases the concentration of  $\text{OCl}^-(\text{aq})$  in this equilibrium system.

23. \_\_\_\_ Which term refers to the difference between the potential energy of the products and the potential energy of the reactants for any chemical change?

(1) heat of deposition

(2) heat of fusion

(3) heat of reaction

(4) heat of vaporization

Given the balanced equation representing a reaction:

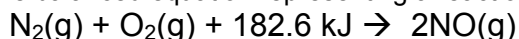

On the labeled axes, draw a potential energy diagram for this reaction.

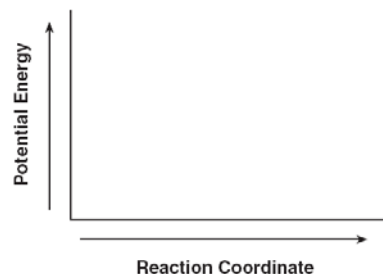

Base your answers to questions 24 and 25 on the information below.

A beaker contains 100.0 milliliters of a dilute aqueous solution of ethanoic acid at equilibrium. The equation below represents this system.

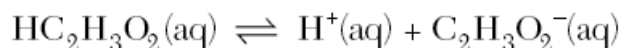

24. Compare the rate of the forward reaction to the rate of the reverse reaction for this system.

25. Describe what happens to the concentration of  $\text{H}^+(\text{aq})$  when 10 drops of concentrated  $\text{HC}_2\text{H}_3\text{O}_2(\text{aq})$  are added to this system.

Base your answers to questions 26 through 28 on the information below.

“Hand Blasters” is a toy that consists of a set of two ceramic balls, each coated with a mixture of sulfur and potassium chlorate,  $\text{KClO}_3$ . When the two balls are struck together, a loud popping noise is produced as sulfur and potassium chlorate react with each other.

26. Balance the equation for the “Hand Blaster” reaction, using the smallest whole-number coefficients.



27. Identify *one* source of the activation energy for this reaction

28. Determine the oxidation number of chlorine in the reactant that contains chlorine.

Name: \_\_\_\_\_

- \_\_\_\_ Which changes occur when  $\text{Pt}^{2+}$  is reduced?
  - (1) The  $\text{Pt}^{2+}$  gains electrons and its oxidation number increases.
  - (2) The  $\text{Pt}^{2+}$  gains electrons and its oxidation number decreases.
  - (3) The  $\text{Pt}^{2+}$  loses electrons and its oxidation number increases.
  - (4) The  $\text{Pt}^{2+}$  loses electrons and its oxidation number decreases.
- \_\_\_\_ Which balanced equation represents an oxidation-reduction reaction?
  - (1)  $\text{BaCl}_2 + \text{Na}_2\text{SO}_4 \leftrightarrow \text{BaSO}_4 + 2\text{NaCl}$
  - (2)  $\text{C} + \text{H}_2\text{O} \leftrightarrow \text{CO} + \text{H}_2$
  - (3)  $\text{CaCO}_3 \leftrightarrow \text{CaO} + \text{CO}_2$
  - (4)  $\text{Mg}(\text{OH})_2 + 2\text{HNO}_3 \leftrightarrow \text{Mg}(\text{NO}_3)_2 + 2\text{H}_2\text{O}$
- \_\_\_\_ Which energy conversion occurs during the operation of a voltaic cell?
  - (1) Chemical energy is spontaneously converted to electrical energy.
  - (2) Chemical energy is converted to electrical energy only when an external power source is provided.
  - (3) Electrical energy is spontaneously converted to chemical energy.
  - (4) Electrical energy is converted to chemical energy only when an external power source is provided.
- \_\_\_\_ What is the total number of electrons in a  $\text{Mg}^{2+}$  ion?
  - (1) 10
  - (2) 12
  - (3) 14
  - (4) 24

Given the balanced ionic equation representing a reaction:

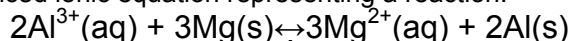

- \_\_\_\_ In this reaction, electrons are transferred from
  - (1) Al to  $\text{Mg}^{2+}$
  - (2)  $\text{Al}^{3+}$  to Mg
  - (3) Mg to  $\text{Al}^{3+}$
  - (4)  $\text{Mg}^{2+}$  to Al

The unbalanced equation below represents the decomposition of potassium chlorate.



- Determine the oxidation number of chlorine in the reactant. 

--
- \_\_\_\_ What is the net charge on an ion that has 9 protons, 11 neutrons, and 10 electrons?
  - (1) 1+
  - (2) 2+
  - (3) 1-
  - (4) 2-
- \_\_\_\_ Which group on the Periodic Table of the Elements contains elements that react with oxygen to form compounds with the general formula  $\text{X}_2\text{O}$ ?
  - (1) Group 1
  - (2) Group 2
  - (3) Group 14
  - (4) Group 18

Given the balanced equation representing the reaction occurring in a voltaic cell:

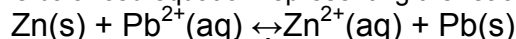

- \_\_\_\_ In the completed external circuit, the electrons flow from
  - (1)  $\text{Pb}(\text{s})$  to  $\text{Zn}(\text{s})$
  - (2)  $\text{Pb}^{2+}(\text{aq})$  to  $\text{Zn}^{2+}(\text{aq})$
  - (3)  $\text{Zn}(\text{s})$  to  $\text{Pb}(\text{s})$
  - (4)  $\text{Zn}^{2+}(\text{aq})$  to  $\text{Pb}^{2+}(\text{aq})$
- \_\_\_\_ Which balanced equation represents a redox reaction?
  - (1)  $\text{CuCO}_3(\text{s}) \leftrightarrow \text{CuO}(\text{s}) + \text{CO}_2(\text{g})$
  - (2)  $2\text{KClO}_3(\text{s}) \leftrightarrow 2\text{KCl}(\text{s}) + 3\text{O}_2(\text{g})$
  - (3)  $\text{AgNO}_3(\text{aq}) + \text{KCl}(\text{aq}) \leftrightarrow \text{AgCl}(\text{s}) + \text{KNO}_3(\text{aq})$
  - (4)  $\text{H}_2\text{SO}_4(\text{aq}) + 2\text{KOH}(\text{aq}) \leftrightarrow \text{K}_2\text{SO}_4(\text{aq}) + 2\text{H}_2\text{O}(\text{l})$

Given the unbalanced ionic equation:

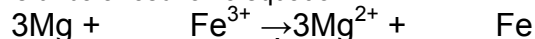

- \_\_\_\_ When this equation is balanced, both  $\text{Fe}^{3+}$  and Fe have a coefficient of
  - (1) 1, because a total of 6 electrons is transferred
  - (2) 2, because a total of 6 electrons is transferred
  - (3) 1, because a total of 3 electrons is transferred
  - (4) 2, because a total of 3 electrons is transferred

Name: \_\_\_\_\_

A student collects the materials and equipment below to construct a voltaic cell.

- two 250-mL beakers
- wire and a switch
- one strip of magnesium
- one strip of copper
- 125 mL of 0.20 M  $\text{Mg}(\text{NO}_3)_2(\text{aq})$
- 125 mL of 0.20 M  $\text{Cu}(\text{NO}_3)_2(\text{aq})$

12. \_\_\_\_ Which additional item is required for the construction of the voltaic cell?  
(1) an anode (2) a battery (3) a cathode (4) a salt bridge

13. What is the oxidation number of nitrogen in  $\text{NO}(\text{g})$ ?

Base your answers to questions 14 and 15 on the information below.

Electroplating is an electrolytic process used to coat metal objects with a more expensive and less reactive metal. The diagram below shows an electroplating cell that includes a battery connected to a silver bar and a metal spoon. The bar and spoon are submerged in  $\text{AgNO}_3(\text{aq})$ .

14. Explain why  $\text{AgNO}_3$  is a better choice than  $\text{AgCl}$  for use in this electrolytic process.

15. Explain the purpose of the battery in this cell.

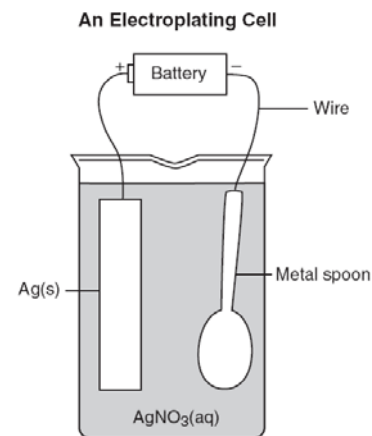

16. \_\_\_\_ In a redox reaction, the total number of electrons lost is  
(1) less than the total number of electrons gained (3) equal to the total number of electrons gained  
(2) greater than the total number of electrons gained (4) equal to the total number of protons gained
17. \_\_\_\_ Which energy conversion occurs in a voltaic cell?  
(1) chemical energy to electrical energy (3) electrical energy to chemical energy  
(2) chemical energy to nuclear energy (4) nuclear energy to electrical energy
18. \_\_\_\_ Which metal is more active than Ni and *less* active than Zn?  
(1) Cu (2) Cr (3) Mg (4) Pb
19. \_\_\_\_ In which compound is the ratio of metal ions to nonmetal ions 1 to 2?  
(1) calcium bromide (3) calcium phosphide  
(2) calcium oxide (4) calcium sulfide
20. \_\_\_\_ Reduction occurs at the cathode in  
(1) electrolytic cells, only (3) both electrolytic cells and voltaic cells  
(2) voltaic cells, only (4) neither electrolytic cells nor voltaic cells

Name: \_\_\_\_\_

- \_\_\_\_ An Arrhenius base yields which ion as the only negative ion in an aqueous solution?  
(1) hydride ion      (2) hydrogen ion      (3) hydronium ion      (4) hydroxide ion
- \_\_\_\_ According to one acid-base theory, a water molecule acts as an acid when the water molecule  
(1) accepts an H<sup>+</sup>      (2) accepts an OH<sup>-</sup>      (3) donates an H<sup>+</sup>      (4) donates an OH<sup>-</sup>
- \_\_\_\_ Which two formulas represent Arrhenius acids?  
(1) CH<sub>3</sub>COOH and CH<sub>3</sub>CH<sub>2</sub>OH      (3) KHCO<sub>3</sub> and KHSO<sub>4</sub>  
(2) HC<sub>2</sub>H<sub>3</sub>O<sub>2</sub> and H<sub>3</sub>PO<sub>4</sub>      (4) NaSCN and Na<sub>2</sub>S<sub>2</sub>O<sub>3</sub>

Information related to a titration experiment is given in the balanced equation and table below.

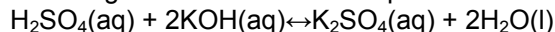

**Titration Experiment Results**

volume of H <sub>2</sub> SO <sub>4</sub> (aq) used	12.0 mL
concentration of H <sub>2</sub> SO <sub>4</sub> (aq)	?
volume of KOH(aq) used	36.0 mL
concentration of KOH(aq)	0.16 M

- \_\_\_\_ Based on the equation and the titration results, what is the concentration of the H<sub>2</sub>SO<sub>4</sub>(aq)?  
(1) 0.12 M      (2) 0.16 M      (3) 0.24 M      (4) 0.96 M

Base your answers to questions 5 and 6 on the information below.

Sulfur dioxide, SO<sub>2</sub>, is one gas produced when fossil fuels are burned. When this gas reacts with water in the atmosphere, an acid is produced forming acid rain. The pH of the water in a lake changes when acid rain collects in the lake. Two samples of the same rainwater are tested using two indicators. Methyl orange is yellow in one sample of this rainwater. Litmus is red in the other sample of this rainwater.

- Identify a possible pH value for the rainwater that was tested. \_\_\_\_\_
- Write the formula for *one* substance that can neutralize the lake water affected by acid rain. \_\_\_\_\_
- \_\_\_\_ Which formula represents a hydronium ion?  
(1) H<sub>3</sub>O<sup>+</sup>      (2) NH<sub>4</sub><sup>+</sup>      (3) OH<sup>-</sup>      (4) HCO<sub>3</sub><sup>-</sup>
- \_\_\_\_ Which compound is an Arrhenius acid?  
(1) H<sub>2</sub>SO<sub>4</sub>      (2) KCl      (3) NaOH      (4) NH<sub>3</sub>

The table below shows the color of the indicators methyl orange and litmus in two samples of the same solution.

**Results of Acid-Base Indicator Tests**

Indicator	Color Result from the Indicator Test
methyl orange	yellow
litmus	red

- \_\_\_\_ Which pH value is consistent with the indicator results?  
(1) 1      (2) 5      (3) 3      (4) 10
- \_\_\_\_ What is the pH of a solution that has a hydronium ion concentration 100 times greater than a solution with a pH of 4?  
(1) 5      (2) 2      (3) 3      (4) 6

Name: \_\_\_\_\_

11. What color is bromcresol green after it is added to a sample of NaOH(aq)? \_\_\_\_\_
12. \_\_\_\_\_ Which substance is an Arrhenius acid?  
(1) Ba(OH)<sub>2</sub>                      (2) CH<sub>3</sub>COOCH<sub>3</sub>                      (3) H<sub>3</sub>PO<sub>4</sub>                      (4) NaCl
13. \_\_\_\_\_ Which compound releases hydroxide ions in an aqueous solution?  
(1) CH<sub>3</sub>COOH                      (2) CH<sub>3</sub>OH                      (3) HCl                      (4) KOH
14. \_\_\_\_\_ What are the products of a reaction between KOH(aq) and HCl(aq)?  
(1) H<sub>2</sub> and KClO                      (2) H<sub>2</sub>O and KCl                      (3) KH and HClO                      (4) KOH and HCl
15. \_\_\_\_\_ Which volume of 0.10 M NaOH(aq) exactly neutralizes 15.0 milliliters of 0.20 M HNO<sub>3</sub>(aq)?  
(1) 1.5 mL                      (2) 7.5 mL                      (3) 3.0 mL                      (4) 30. mL
16. \_\_\_\_\_ Which indicator, when added to a solution, changes color from yellow to blue as the pH of the solution is changed from 5.5 to 8.0?  
(1) bromcresol green                      (2) bromthymol blue                      (3) litmus                      (4) methyl orange
17. \_\_\_\_\_ The pH of an aqueous solution changes from 4 to 3 when the hydrogen ion concentration in the solution is  
(1) decreased by a factor of  $\frac{3}{4}$                       (3) increased by a factor of  $\frac{4}{3}$   
(2) decreased by a factor of 10                      (4) increased by a factor of 10

Base your answers to questions 18 through 20 on the information below.

A laboratory worker filled a bottle with a hydrochloric acid solution. Another bottle was filled with methanol, while a third bottle was filled with a sodium hydroxide solution. However, the worker neglected to label each bottle. After a few days, the worker could not remember which liquid was in each bottle. The worker needed to identify the liquid in each bottle. The bottles were labeled A, B, and C. Using materials found in the lab (indicators, conductivity apparatus, and pieces of Mg metal), the worker tested samples of liquid from each bottle. The test results are shown in the table below.

**Table of Tests and Results**

Test	Test Results		
	Bottle A	Bottle B	Bottle C
methyl orange indicator	yellow	yellow	yellow
bromthymol blue indicator	blue	green	yellow
electrical conductivity	conductor	nonconductor	conductor
reactivity with Mg metal	no reaction	no reaction	reaction

18. Using the test results, state how the worker differentiated the bottle that contained methanol from the other two bottles.

19. The worker concluded that bottle C contained hydrochloric acid. Identify *one* test and state the corresponding test result that supports this conclusion.

20. Explain, in terms of pH, why the methyl orange indicator test results were the same for each of the three liquids.

Name: \_\_\_\_\_

1. \_\_\_\_ What is the total number of carbon atoms in a molecule of ethanoic acid?  
(1) 1                    (2) 2                    (3) 3                    (4) 4

Given the formulas for two compounds:

2. \_\_\_\_ These compounds differ in  
(1) gram-formula mass                    (3) percent composition by mass  
(2) molecular formula                    (4) physical properties at STP
3. \_\_\_\_ A double carbon-carbon bond is found in a molecule of  
(1) pentane            (2) pentene            (3) pentyne            (4) pentanol
4. \_\_\_\_ Which compound is an unsaturated hydrocarbon?  
(1) hexanal            (2) hexane            (3) hexanoic acid            (4) hexyne

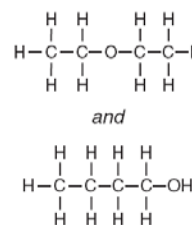

5. \_\_\_\_ The organic compound represented by the condensed structural formula  $\text{CH}_3\text{CH}_2\text{CH}_2\text{CHO}$  is classified as an  
(1) alcohol            (2) aldehyde            (3) ester            (4) ether

6. In the space provided, draw a structural formula for a molecule of methanethiol.



Given the balanced equation for producing bromomethane:

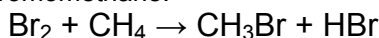

Identify the type of organic reaction shown.

7. \_\_\_\_ A molecule of butane and a molecule of 2-butene both have the same total number of  
(1) carbon atoms            (2) hydrogen atoms            (3) single bonds            (4) double bonds
8. \_\_\_\_ Which general formula represents the homologous series of hydrocarbons that includes the compound 1-heptyne?  
(1)  $\text{C}_n\text{H}_{2n-6}$             (2)  $\text{C}_n\text{H}_{2n-2}$             (3)  $\text{C}_n\text{H}_{2n}$             (4)  $\text{C}_n\text{H}_{2n+2}$
9. \_\_\_\_ Which two compounds are isomers of each other?  
(1)  $\text{CH}_3\text{CH}_2\text{COOH}$  and  $\text{CH}_3\text{COOCH}_2\text{CH}_3$   
(2)  $\text{CH}_3\text{CH}_2\text{CHO}$  and  $\text{CH}_3\text{COCH}_3$   
(3)  $\text{CH}_3\text{CHBrCH}_3$  and  $\text{CH}_2\text{BrCHBrCH}_3$   
(4)  $\text{CH}_3\text{CHOHCH}_3$  and  $\text{CH}_3\text{CHOHCH}_2\text{OH}$
10. \_\_\_\_ Which formula represents an unsaturated hydrocarbon?

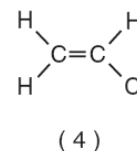
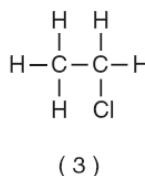
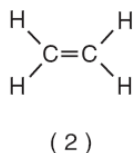
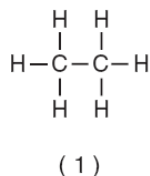

11. \_\_\_\_ A compound has a molar mass of 90. grams per mole and the empirical formula  $\text{CH}_2\text{O}$ . What is the molecular formula of this compound?  
(1)  $\text{CH}_2\text{O}$             (2)  $\text{C}_2\text{H}_4\text{O}_2$             (3)  $\text{C}_3\text{H}_6\text{O}_3$             (4)  $\text{C}_4\text{H}_8\text{O}_4$

Given the formula of a substance:

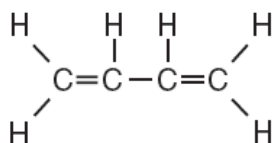

12. \_\_\_\_ What is the total number of shared electrons in a molecule of this substance?  
(1) 22            (2) 11            (3) 9            (4) 6

Name: \_\_\_\_\_

Base your answers to questions 13 through 15 on the information below.

The incomplete equation below represents an esterification reaction. The alcohol reactant is represented by X.

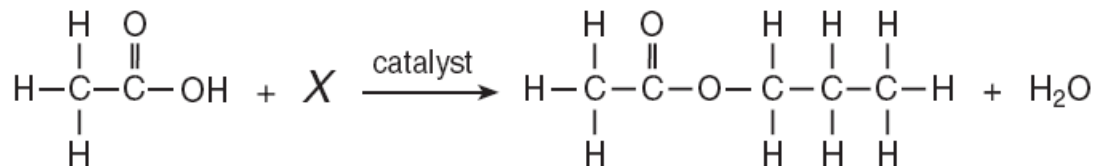

13. On the structural formula, circle the acid functional group, only.

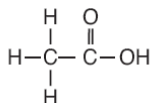

14. Write an IUPAC name for the reactant represented by its structural formula in this equation.

15. In the space provided, draw the structural formula for the alcohol represented by X.

16. \_\_\_\_\_ Which formula represents an alkene?

- (1) C<sub>2</sub>H<sub>6</sub>      (2) C<sub>3</sub>H<sub>6</sub>      (3) C<sub>4</sub>H<sub>10</sub>      (4) C<sub>5</sub>H<sub>12</sub>

17. \_\_\_\_\_ What is the total number of pairs of electrons shared between the carbon atom and the oxygen atom in a molecule of methanal?

- (1) 1      (2) 2      (3) 3      (4) 4

18. \_\_\_\_\_ Which compound is a saturated hydrocarbon?

- (1) CH<sub>2</sub>CH<sub>2</sub>      (2) CH<sub>3</sub>CH<sub>3</sub>      (3) CH<sub>3</sub>CHO      (4) CH<sub>3</sub>CH<sub>2</sub>OH

19. \_\_\_\_\_ A molecule of a compound contains a total of 10 hydrogen atoms and has the general formula C<sub>n</sub>H<sub>2n+2</sub>. Which prefix is used in the name of this compound?

- (1) but-      (2) dec-      (3) oct-      (4) pent-

20. Write the empirical formula for the compound C<sub>8</sub>H<sub>18</sub>.

A beaker contains 100.0 milliliters of a dilute aqueous solution of ethanoic acid at equilibrium. The equation below represents this system.

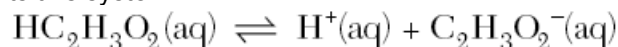

21. In the space provided, draw a structural formula for ethanoic acid.

Name: \_\_\_\_\_

Base your answers to questions 22 through 24 on the information below.

The compound 1,2-ethanediol can be mixed with water. This mixture is added to automobile radiators as an engine coolant. The cooling system of a small van contains 6690 grams of 1,2-ethanediol. Some properties of water and 1,2-ethanediol are given in the table below.

### Properties of Water and 1,2-ethanediol

Property	Water (H <sub>2</sub> O)	1,2-ethanediol (CH <sub>2</sub> OHCH <sub>2</sub> OH)
gram-formula mass (g/mol)	18.0	62.0
boiling point at standard pressure (°C)	100.0	197.2

22. Identify the class of organic compounds to which 1,2-ethanediol belongs.

23. State, in terms of molecular polarity, why 1,2-ethanediol is soluble in water.

24. In the space provided, calculate the total number of moles of 1, 2-ethanediol in the small van's cooling system. Your response must include *both* a correct numerical setup and the calculated result.

Base your answers to questions 25 and 26 on the information below.

The graph below shows the relationship between boiling point and molar mass at standard pressure for pentane, hexane, heptane, and nonane.

25. Octane has a molar mass of 114 grams per mole. According to this graph, what is the boiling point of octane at standard pressure?

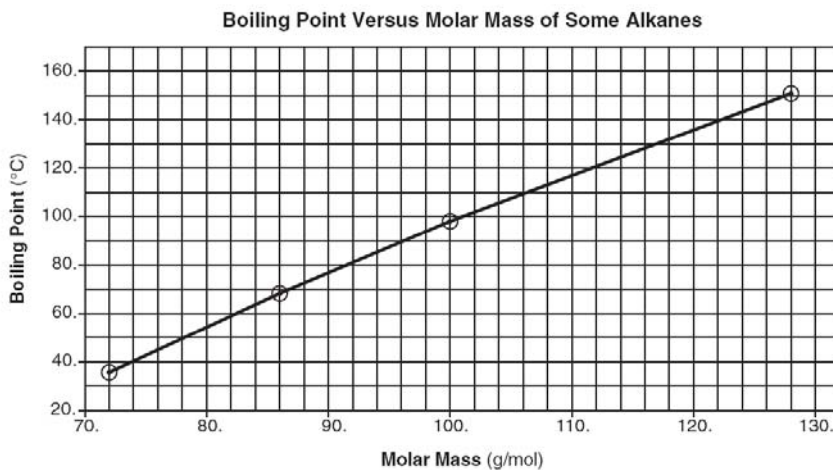

26. State the relationship between molar mass and the strength of intermolecular forces for the selected alkanes.



Name: \_\_\_\_\_

13. \_\_\_\_ Which nuclear equation represents a natural transmutation?

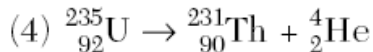
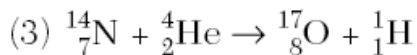
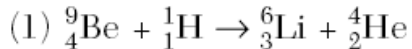

14. \_\_\_\_ A nuclear fission reaction and a nuclear fusion reaction are similar because both reactions  
(1) form heavy nuclides from light nuclides (3) release a large amount of energy  
(2) form light nuclides from heavy nuclides (4) absorb a large amount of energy

Base your answers to questions 15 and 16 on the information below.

The fossilized remains of a plant were found at a construction site. The fossilized

remains contain  $\frac{1}{16}$  the amount of carbon-14 that is present in a living plant.

15. Determine the approximate age of these fossilized remains.

--

16. Complete the nuclear equation for the decay of C-14. Your response must include the atomic number, the mass number, and the symbol of the missing particle.

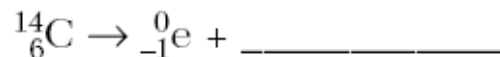

17. \_\_\_\_ Which reaction converts an atom of one element to an atom of another element?  
(1) combustion (2) polymerization (3) saponification (4) transmutation

18. \_\_\_\_ Which nuclear emission has the greatest mass?  
(1) alpha particle (2) beta particle (3) gamma ray (4) positron

19. \_\_\_\_ Which two radioisotopes have the same decay mode?  
(1)  ${}^{37}\text{Ca}$  and  ${}^{53}\text{Fe}$  (2)  ${}^{220}\text{Fr}$  and  ${}^{60}\text{Co}$  (3)  ${}^{37}\text{K}$  and  ${}^{42}\text{K}$  (4)  ${}^{99}\text{Tc}$  and  ${}^{19}\text{Ne}$

20. \_\_\_\_ Which list of nuclear emissions is arranged in order from the *least* penetrating power to the greatest penetrating power?  
(1) alpha particle, beta particle, gamma ray (3) gamma ray, beta particle, alpha particle  
(2) alpha particle, gamma ray, beta particle (4) beta particle, alpha particle, gamma ray

21. \_\_\_\_ One benefit of nuclear fission reactions is  
(1) nuclear reactor meltdowns (3) biological exposure  
(2) storage of waste materials (4) production of energy

22. \_\_\_\_ Which fraction of an original 20.00-gram sample of nitrogen-16 remains unchanged after 36.0 seconds?

(1)  $\frac{1}{5}$  (3)  $\frac{1}{16}$

(2)  $\frac{1}{8}$  (4)  $\frac{1}{32}$

23. \_\_\_\_ Which radioactive isotope is used in treating cancer?  
(1) carbon-14 (2) cobalt-60 (3) lead-206 (4) uranium-238